

- A thickening in the breast tissue
- A nipple becoming inverted (turned in)
- A lump or thickening behind the nipple
- A rash (like eczema) affecting the nipple
- A bloodstained discharge from the nipple (this is very rare)
- A swelling or lump in the armpit

Pain in the breast is not usually a symptom of breast cancer. In fact many healthy women feel that their breasts feel lumpy and quite tender before a period. Some types of benign breast lumps can be painful. Often there are no outward signs of breast cancer that you can see or feel. Even if you do have one or more of these signs, it still doesn't mean you have breast cancer. Most breast lumps turn out to be benign (not cancerous). However, it is important that you tell your doctor immediately if you experience any worrying symptoms. Having your doctor take a look may ease your worry, and if anything is found, you'll be able to take care of it quickly.

Useful Websites (www):

Telephone Numbers:

breakthrough.org.uk

Breakthrough Breast Cancer:
08080 100 200

breastcancerogenetics.co.uk

Hereditary Breast Cancer Helpline:
01629 813000

breastcancercare.org.uk

Breast Cancer Care: 0808 800 6000

macmillan.org.uk

Macmillan Cancer Support: 0808 808 0000

ovacome.org.uk

Ovacome Support Service: 0845 371 0554

cancerhelpuk.org

CancerHelp UK (Nurse Line):
0808 800 4040

Birmingham Women's NHS Foundation Trust is not responsible for the content of third-party information and does not endorse any product, view or process or opinion from such sources.

Birmingham Women's NHS Foundation Trust
Edgbaston, Birmingham, B15 2TG
Telephone: 0121 472 1377
Fax: 0121 627 2602

Reference Number: CG 6/HBOC
 Authors: C Chapman, A Cuthbert, C Dolling, A Taylor
 Authors titles: Consultant Geneticist/Genetic Counsellors
 Reviewed: June 2011 Next Review: June 2014

Birmingham Women's 

NHS Foundation Trust

Hereditary Breast and Ovarian Cancer (HBOC)

Information for women with an increased lifetime risk of breast and ovarian cancer

If you need more advice please contact:

West Midlands Family Cancer Service
 Clinical Genetics Unit
 Birmingham Women's NHS Foundation Trust
 Mindelsohn Way
 Edgbaston
 Birmingham
 B15 2TG

Telephone: 0121 607 4757

Fax: 0121 623 6949

Email: wmfac@bwhct.nhs.uk

What is Hereditary Breast and Ovarian Cancer (HBOC)?

Hereditary Breast and Ovarian Cancer is a genetic condition which causes women in a family to have an increased risk of developing breast and ovarian cancer. In some families there also may be an increased susceptibility to other cancers, such as male breast cancer, prostate cancer, malignant melanoma and pancreatic cancer.

How do I know if the cancers in my family are due to HBOC?

HBOC is uncommon. Fewer than 1 in 20 women who develop breast cancer have HBOC. In most families cancer is **not** inherited or passed down through the generations. HBOC might be present in your family if:

- **Several women had breast cancer or ovarian cancer**
- **Someone was diagnosed at a much younger age than is usual**
- **A relative had breast cancer more than once, or had early breast and ovarian cancer**
- **A male relative had breast cancer as well as female relatives**
- **Multiple generations on one side of the family were affected by these cancers**

In the UK, breast cancer affects 1 in 8 (12.5%) women during their lifetime. The great majority are diagnosed over the age of 60. Ovarian cancer is less common. About 1 in 50 (2%) women will develop ovarian cancer in their lifetime. Most of them will have been through menopause. Prostate cancer affects about 1 in 9 men (11%), but mostly those over the age of 70. The risk of male breast cancer is very small, about 1 in 2000.

How does HBOC run in families?

HBOC is caused by an alteration in a gene. Genes are messages which control the working of the body. Most genes come in matching pairs; one copy of each is inherited from the mother, the other copy from the father, as shown in the diagram.

Only a single genetic alteration is needed to cause HBOC. If someone has HBOC it means they have a normal copy of the gene but they also carry an altered copy. Each time they have a child there is a fifty-fifty (50%) chance that they will pass on the normal copy and a fifty-fifty chance they will pass on the altered one.

not required unless you have other unrelated gynaecological problems. You might be offered keyhole surgery to remove your ovaries and tubes. You can get further advice about this from your Gynaecologist.

What about men in HBOC families?

Men in BRCA1 families are not thought to be at significantly increased risk of cancer. Some studies suggest there may be a slight increase in the risk of prostate cancer. Men in BRCA2 families have an increased risk of breast and prostate cancer. Breast screening is not recommended because the overall chance is still low, about 7%.

The increased risk of prostate cancer is debated but may be between 20 to 25% (up to 1-in-4) over a lifetime. We would suggest men at increased risk consider prostate screening from the age of 45. This involves a blood test to measure their PSA levels. We recommend referral to a Urologist who has special knowledge of these matters.

Does my risk change with age?

An individual who has **not** had a gene test or breast/ovarian cancer has a gradually decreasing chance of carrying the altered gene as they get older. This also means the risk to their children declines. This may become clearer by the time the next generation reaches the age when cancer screening would usually start.

Are there any symptoms I should look out for?

Diagnosing **ovarian** cancer can be difficult because symptoms are often similar to those caused by less serious common conditions. If you have any of the following symptoms it is **unlikely** they are due to a serious problem. It is still important that you discuss them with your doctor. Ask them if they have considered ovarian cancer. In particular, you should ask your GP about ovarian cancer if you experience any of these three symptoms on most days:

- **Persistent pelvic and stomach pain**
- **Increased abdominal size/persistent bloating - not bloating that comes and goes**
- **Difficulty eating and feeling full quickly**

In most women, **breast cancer** is first noticed as a painless lump in the breast. Other signs may include:

- **A change in the size or shape of a breast**
- **Dimpling of the skin of the breast**

supply to the skin. Therefore, loss of some skin tissue is a recognised complication. An artificial nipple can be reconstructed later.

Simple (total) mastectomy involves removing most of the breast tissue and the skin.

Breast reconstruction can be with an artificial or natural implant. Existing muscle or some fatty tissue can be used as a natural implant.

There are advantages and disadvantages to each procedure. You would be able to discuss these with the surgical team.

Ovarian screening

If you have an increased risk of ovarian cancer we will suggest referring you to a Gynaecologist with expertise in oncology. They will discuss the different options with you. Screening for ovarian cancer involves an internal (transvaginal) ultrasound scan every year and a four-monthly blood test called CA125.

Unfortunately, these procedures have not proven to be beneficial in detecting early cancers. However, this is the only screening method available at present. A national screening study is evaluating this and you might be invited to join in. In premenopausal women screening is more complicated because normal ovaries produce small cysts each month before ovulation. This may complicate the picture so you might be recalled even if it turns out to be normal.

CA125 is not a cancer test but can detect changes in the ovaries. These changes might not be cancerous but may need further investigations. Ovarian cancer screening usually starts from the age of 35, even if you are known to carry an alteration in the BRCA1 or BRCA2 gene. It is important to remember that ovary screening is not the same as cervical screening (smear tests) which is done at your GP surgery.

Risk-reducing surgery of the ovaries (Oophorectomy)

Removal of the ovaries and fallopian tubes reduces the risk of ovarian cancer by more than 90%. In pre-menopausal women it also reduces the risk of breast cancer by at least a third. If performed in pre-menopausal women, oophorectomy causes an immediate menopause. This usually requires Hormone Replacement Therapy (HRT) until the age of natural menopause (around 50 years of age). HRT given in this way will **not** increase the risk of breast cancer.

The risk of womb cancer and cervical cancer does not appear to be increased in BRCA1 and BRCA2 carriers. Therefore, a full hysterectomy is

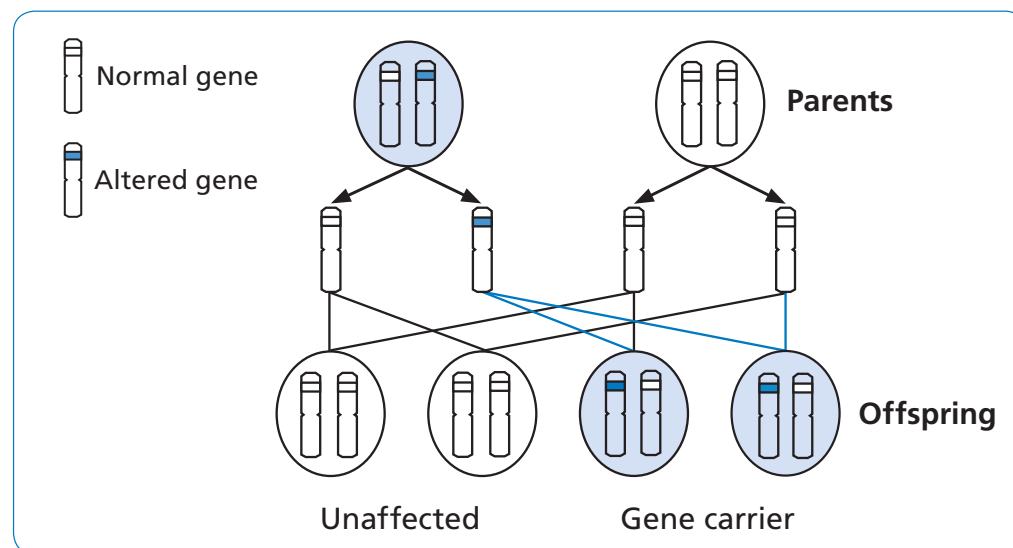

Women AND men can carry an altered copy of the gene, so HBOC can be inherited from either parent. Therefore, the father's family history of cancer also matters.

HBOC is more likely in a family if at least three relatives on the same side of the family had early breast or ovarian cancer. However, HBOC might also be diagnosed if an altered gene has already been found in an individual with cancer regardless of their family history.

Which genes cause HBOC?

There are two genes which we know give rise to HBOC. They are called BRCA1 and BRCA2. There may be other important genes which have not yet been discovered. In some populations certain alterations in either BRCA1 or BRCA2 are more frequent than normal. Among others, this applies to those with Ashkenazi Jewish or Eastern European ancestors.

What is the risk of developing breast and ovarian cancer?

A woman who inherits an altered BRCA1 or BRCA2 gene will not always get cancer but her risk of developing breast or ovarian cancer during her lifetime is greatly increased.

For women with a proven alteration in either BRCA1 or BRCA2, the risk of developing breast cancer before the age of 80 is approximately 80%. The risk of ovarian cancer is lower and is different for the two genes. The lifetime risk of ovarian cancer for proven BRCA1 carriers is approximately 40-60%. For BRCA2 carriers the risk is lower, about 15-30%.

These risk figures are only for those who are known to carry an alteration in BRCA1 or BRCA2. If you have not been tested for a gene alteration your risk of cancer is a lot lower. It would depend on how closely related you are to those with cancer.

In BRCA2 families there is also an increased risk of prostate cancer and male breast cancer. The lifetime risk of prostate cancer is 20- 25%, whereas for male breast cancer it is 6-7%.

Gene tests

Sometimes we can offer a test to find out if cancers in a family are due to an altered BRCA1 or BRCA2 gene. A genetic test involves a family member who had breast or ovarian cancer giving a blood sample. Before a gene test is carried out they need to carefully discuss it with their Geneticist or Genetic Counsellor. These initial tests usually take about two months to complete. If an alteration is found in someone with cancer it is then possible to offer gene testing to other family members to see if they have inherited it. However, not to all HBOC families have identifiable genetic alterations. This means we are not able to offer a gene test to all families.

If **no** genetic alteration is found in your family we would not be able to offer genetic testing to other relatives. However, we would still be able to advise you about cancer screening or risk-reducing surgery. Our advice would be based on your family history.

If a BRCA1 or BRCA2 alteration is identified it would allow other relatives to have a similar test to see if they also carry it. The results of these tests might be difficult to come to terms with. Also, there would be implications for cancer screening. Therefore, we would want to discuss the possible benefits and disadvantages of having a test before going ahead.

If you had a genetic test and were found to carry the gene alteration, we would discuss with you any options for screening and for reducing your risk. Alternatively, if you had a genetic test and it showed you did **not** carry the alteration your risk would not be increased and no extra screening would be suggested. However, we would still recommend you have breast screening provided by the NHS National Breast Screening Programme at the appropriate time. If you decide not to have a genetic test we would not be able to confirm your actual risk of breast or ovarian cancer. We would still recommend extra breast and ovary screening and discuss risk-reducing surgery if you wish. If other family members or their doctors would like further information or advice we would be pleased to help them.

What can you do if you are at increased risk?

If you are at increased risk of breast and ovarian cancer you have several options. Although you may have a high lifetime risk, your actual risk over the next 10 years will still be low, especially if you are under 30. Depending on your age and personal choices you might want to manage your risk differently to other family members.

Women considering risk-reducing mastectomy may choose to defer surgery until they are entering the age group where the risk is most significant. For younger women there is also the possibility that other treatments may be developed in the next 10-20 years which might provide better alternatives.

Breast screening

Most women will be offered regular mammograms (X-rays of the breast) and a breast examination by a clinician. Sometimes the clinician will decide to use other types of examination including ultrasound scan or MRI of the breast because breast screening is difficult in younger women who tend to have denser breast tissue.

Depending on your personal risk, breast screening might be offered earlier than usual. If you are known to carry a BRCA1 or BRCA2 alteration it would be offered from the age of 30.

Mammograms will sometimes detect changes in the breast which are harmless but might require further investigations. It is also important to know that not all cancers will be picked up by screening. You should be 'breast aware' and report any unusual symptoms to your doctor as soon as possible.

Breast screening does not prevent the development of cancer. It is given in the hope of picking up cancer at an early stage where treatment is more likely to succeed. However, it might still involve surgery and possibly chemotherapy and radiotherapy too.

Risk-reducing surgery of the breast

Double mastectomy with reconstruction reduces the risk of breast cancer by at least 90%. However it involves major surgery with a risk of complications. It usually involves breast and plastic surgery teams. It may also have psychological implications. Counselling should be offered with specialist teams and a clinical psychologist.

Subcutaneous mastectomy involves removal of as much breast tissue as possible, including the nipple. There is a risk of interrupting the blood